



# Cambridge O Level

---

**PHYSICS**

**5054/32**

Paper 3 Practical Test

**October/November 2020**

CONFIDENTIAL INSTRUCTIONS

**This document gives details of how to prepare for and administer the practical exam.**

**The information in this document and the identity of any materials supplied by Cambridge International are confidential and must NOT reach candidates either directly or indirectly.**

**The supervisor must complete the report at the end of this document and return it with the scripts.**

---

## INSTRUCTIONS

- If you have any queries regarding these confidential instructions, contact Cambridge International stating the centre number, the syllabus and component number and the nature of the query.  
email      [info@cambridgeinternational.org](mailto:info@cambridgeinternational.org)  
phone      +44 1223 553554

---

This document has **12** pages. Blank pages are indicated.

## General information about practical exams

Centres must follow the guidance on science practical exams given in the *Cambridge Handbook*.

### Safety

Supervisors must follow national and local regulations relating to safety and first aid.

Only those procedures described in the question paper should be attempted.

Supervisors must inform candidates that materials and apparatus used in the exam should be treated with caution. Suitable eye protection should be used where necessary.

The following hazard codes are used in these confidential instructions, where relevant:

<b>C</b>	corrosive	<b>MH</b>	moderate hazard
<b>HH</b>	health hazard	<b>T</b>	acutely toxic
<b>F</b>	flammable	<b>O</b>	oxidising
<b>N</b>	hazardous to the aquatic environment		

Hazard data sheets relating to substances used in this exam should be available from your chemical supplier.

### Before the exam

- The packets containing the question papers must **not** be opened before the exam.
- It is assumed that standard school laboratory facilities, as indicated in the *Guide to Planning Practical Science*, will be available.
- Spare materials and apparatus for the tasks set must be available for candidates, if required.

### During the exam

- It must be made clear to candidates at the start of the exam that they may request spare materials and apparatus for the tasks set.
- Where specified, the supervisor **must** perform the experiments and record the results as instructed. This must be done **out of sight** of the candidates, using the same materials and apparatus as the candidates.
- Any assistance provided to candidates must be recorded in the supervisor's report.
- If any materials or apparatus need to be replaced, for example, in the event of breakage or loss, this must be recorded in the supervisor's report.

### After the exam

- The supervisor must complete a report for each practical session held and each laboratory used.
- Each packet of scripts returned to Cambridge International must contain the following items:
  - the scripts of the candidates specified on the bar code label provided
  - the supervisor's results relevant to these candidates
  - the supervisor's reports relevant to these candidates
  - seating plans for each practical session, referring to each candidate by candidate number
  - the attendance register.

## Specific information for this practical exam

### Number of sets of apparatus

In addition to a few spare sets, the minimum number of sets of apparatus to be provided should be sufficient to enable candidates to spend 20 minutes with the apparatus for each of Questions 1, 2 and 3, and one hour with the apparatus for Question 4. The order in which candidates answer the questions will be determined by the supervisor. Candidates may spend one hour circulating around Questions 1, 2 and 3, followed by an hour on Question 4, or vice versa.

It is assumed that candidates will supply their own calculator and geometrical instruments, such as a set square,  $0^\circ$  to  $180^\circ$  protractor, pair of compasses and 30 cm ruler. Candidates should be advised in advance that they may, if they wish, use wrist-watches with stop-watch facilities, providing that such wrist-watches afford the required precision.

### Question 1

Items to be supplied by the Centre (per set of apparatus, unless otherwise specified):

- three identical springs, (see Note 1)
- two pulleys
- thread
- two 100 g mass hangers and three 100 g masses (see Note 2)
- 30 cm ruler with mm divisions
- stand, three bosses and two clamps
- heavy weight, (see Note 3).

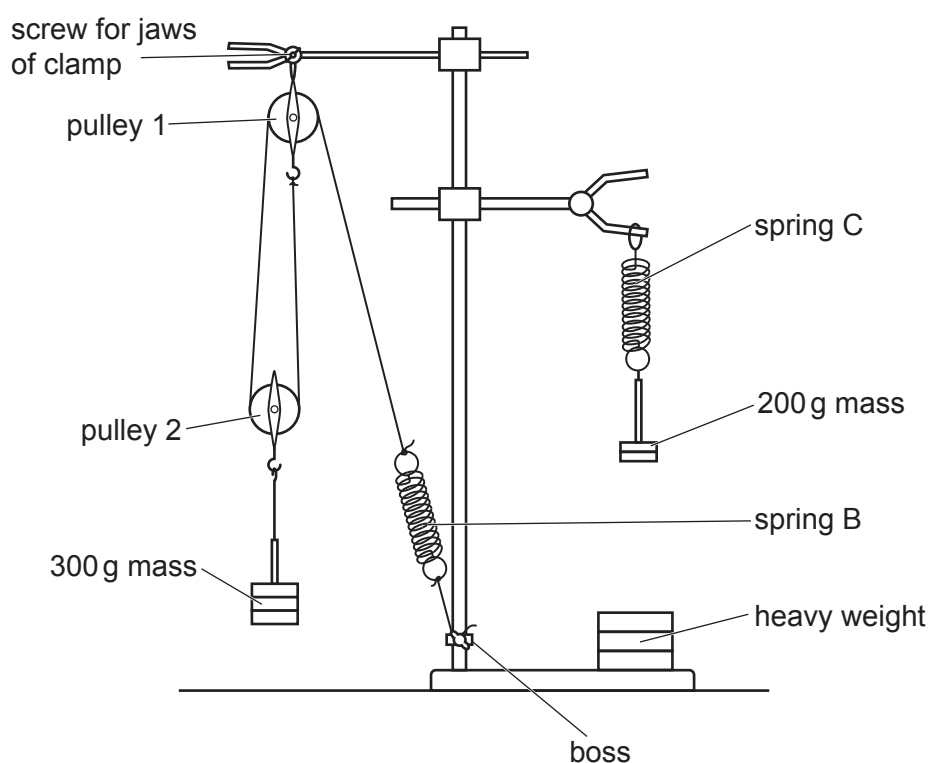
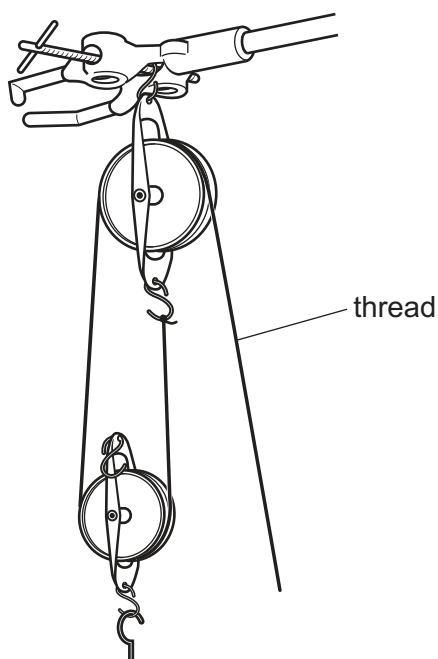

Fig. 1.1

### Notes

1. Three identical expendable steel springs, with a spring constant of approximately 25 N/m, e.g. Philip Harris catalogue number B8G87194.

One spring should be placed on a card marked 'Spring A'. The second spring (spring B) should be attached at one end to a boss at the base of a stand using a short length of thread. Another longer piece of thread (approximately 1.0 m) should be attached to the other end of the spring and looped around the top of pulley 1, then the bottom of pulley 2, and attached to the hook at the bottom of pulley 1. The hook at the top of pulley 1 is then attached to the screw used to adjust the width of the jaws of one of the clamps, as shown in Fig. 1.1 and Fig. 1.2.



**Fig. 1.2**

The clamp should be attached to the stand using the second boss. The second clamp should be attached to the stand using the third boss.

The third spring (Spring C) should be suspended from the jaws of the second clamp as shown in Fig. 1.1.

The stand and clamps must be aligned as shown in Fig. 1.1 with the 300 g mass suspended above the bench at the back of the stand and the 200 g mass suspended above the base.

2. One mass hanger should be suspended from the hook of pulley 2 and two of the 100 g masses should be attached to this hanger. The other mass hanger should be suspended from Spring C and one 100 g mass should be attached to this hanger.
3. A heavy weight should be used to prevent the stand toppling over.

At the changeover, the supervisor should ensure that the apparatus is in the configuration shown in Fig. 1.1, and that a spring A is placed back on the card marked 'Spring A'.

### Information required by Examiners

Sample set of numerical results, clearly marked "supervisor's results", obtained out of sight of the candidates.

## Question 2

Items to be supplied by the Centre (per set of apparatus, unless otherwise specified):

- d.c. power supply (see Note 1)
- electromagnet (see Note 2)
- connecting leads, crocodile clips, and a switch or plug key, (see Note 3)
- resistor of resistance  $10\ \Omega$ , 2W
- ammeter capable of measuring a current up to 1.0A to a precision of 0.01A or better. An analogue or digital meter is suitable
- stand and boss
- plotting compass (see Note 4)
- small wooden rod approx length 10 cm (see Note 4)
- small piece of Blu Tack.

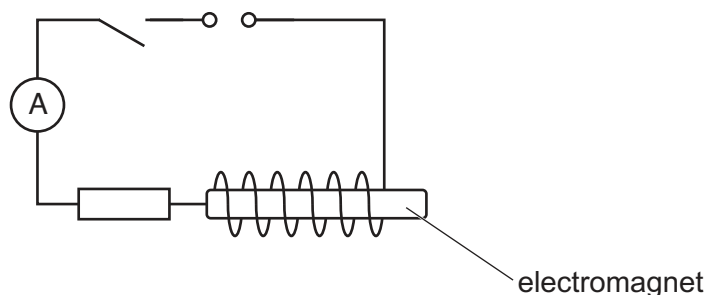

**Fig. 2.1**

## Notes

1. The following are suitable power sources but all the candidates at the centre must be supplied with the same type of source:
  - three 1.5V dry cells in suitable holders or connected in series
  - four 1.2V rechargeable cells in suitable holders or connected in series
  - d.c. power supply of 4V or 5V.

If a variable d.c. power supply is used, the variable control should be taped to prevent candidates altering the output voltage.

2. A suitable electromagnet can be made using a 1 metre length of 26 SWG (0.457 mm diameter) enamelled copper wire coiled tightly around one end of a 7 cm iron nail as shown in Fig. 2.2.

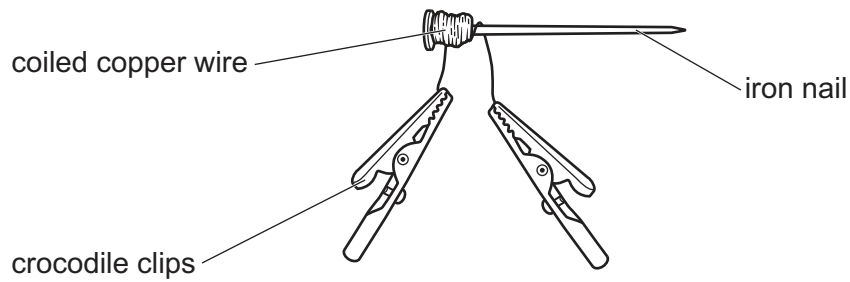

**Fig. 2.2**

The ends of the coil should be rubbed with sandpaper to remove the enamel.

3. The supervisor must set up the circuit shown in Fig. 2.1. One end of the nail used to make the electromagnet should be attached to a boss mounted approximately 10 cm above the bench on a stand.
4. A wooden rod of approximate length 10 cm should be attached to the side of the plotting compass using a small piece of Blu Tack as shown in Fig. 2.3.



**Fig. 2.3**

At the changeover the supervisor should ensure that the circuit is in the configuration shown in Fig. 2.1 with the switch open and that the compass is still attached to the wooden rod.

### Information required by Examiners

None.

### Question 3

Items to be supplied by the Centre (per set of apparatus, unless otherwise specified):

- object A (see Note 1)
- biconvex lens with 15 cm focal length (see Note 2)
- half-metre rule with cm divisions
- small pieces of Blu Tack.

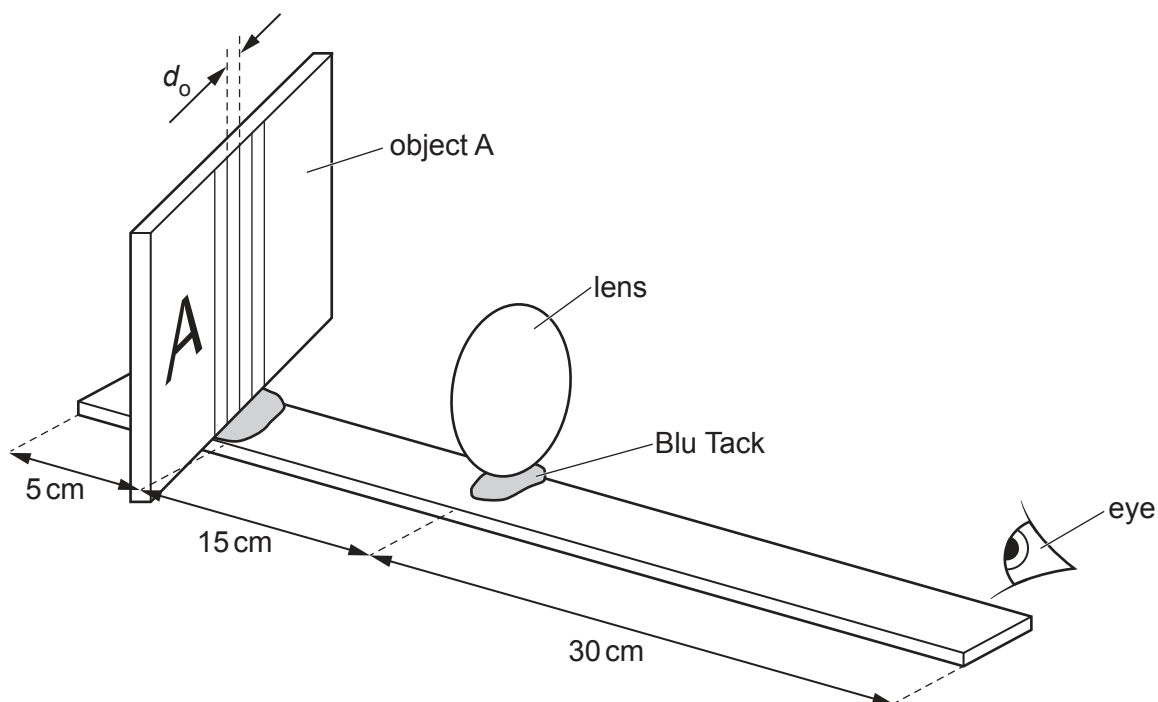

Fig. 3.1

### Notes

1. Object A may be made using a piece of rigid white card approximately 15 cm × 10 cm. Five vertical parallel lines, 5.0 mm apart, should be marked on the card using a fine tipped (0.5 mm) pen. The centre of the five lines should be at the centre of the card. A small piece of Blu Tack should be attached to one side of object A so that it is able to stand vertically on the half-metre rule at the 5.0 cm mark without falling over, as shown in Fig. 3.1. The sides of the object should be perpendicular to the edge of the ruler. The object should be labelled with a large 'A'.
2. A small piece of Blu Tack should be used to attach the lens to the ruler at the 20 cm mark so that the centre of the lens is 15.0 cm from the centre of object A.

At the changeover the supervisor should restore the apparatus to the configuration shown in Fig. 3.1.

### Information required by Examiners

Sample set of numerical results, clearly marked "supervisor's results", obtained out of sight of the candidates.



### Question 4

Items to be supplied by the Centre (per set of apparatus, unless otherwise specified):

- 40 cm length of wire (see Note 1)
- 100 g mass hanger with a pointer (see Note 2)
- seven 100 g slotted masses
- stop-watch reading to 0.1 s or better
- **safety glasses**
- stand, boss and clamp to hold the wire and mass set (see Note 3).

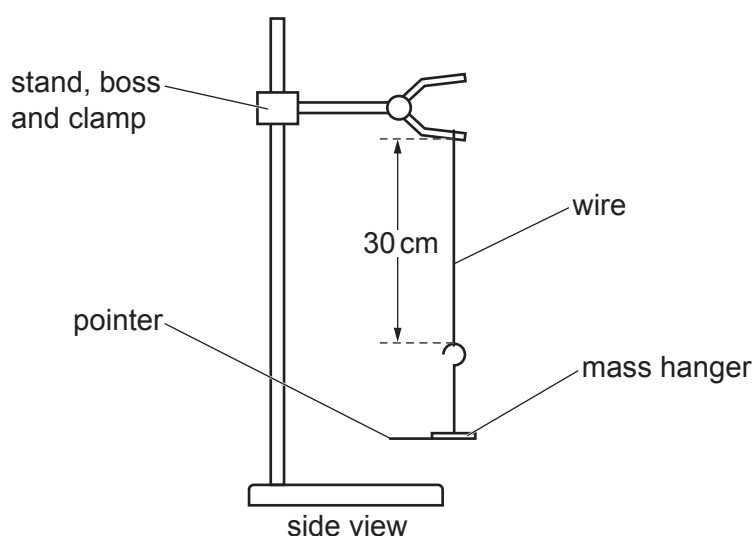

**Fig. 4.1**

### Notes

1. 40 cm length of 30 SWG (0.315 mm diameter) nichrome wire. The wire will be twisted and secured around one prong of the clamp at one end and it will be twisted and secured around the hook of the mass hanger at the other end so that the length between the top of the mass hanger and the clamp is 30 cm.
2. During the experiment candidates will add slotted masses to the mass hanger. A 10 cm wooden splint or piece of stiff card must be taped to the bottom of the mass hanger to act as a pointer. The torsional rotation of the pointer must not be impeded by the stand.
3. Supervisors should set up the apparatus shown in Fig. 4.1 with the mass hanging on the wire just above the base of the stand, with the mass at rest.

At the changeover, the supervisor should restore the apparatus to the configuration shown in Fig. 4.1 with all the slotted masses removed from the mass hanger.

### Information required by Examiners

Sample set of numerical results, clearly marked “supervisor’s results”, obtained out of sight of the candidates.

---

Permission to reproduce items where third-party owned material protected by copyright is included has been sought and cleared where possible. Every reasonable effort has been made by the publisher (UCLES) to trace copyright holders, but if any items requiring clearance have unwittingly been included, the publisher will be pleased to make amends at the earliest possible opportunity.

To avoid the issue of disclosure of answer-related information to candidates, all copyright acknowledgements are reproduced online in the Cambridge Assessment International Education Copyright Acknowledgements Booklet. This is produced for each series of examinations and is freely available to download at [www.cambridgeinternational.org](http://www.cambridgeinternational.org) after the live examination series.

Cambridge Assessment International Education is part of the Cambridge Assessment Group. Cambridge Assessment is the brand name of the University of Cambridge Local Examinations Syndicate (UCLES), which itself is a department of the University of Cambridge.

**Supervisor's report**

Syllabus and component number

				/		
--	--	--	--	---	--	--

Centre number

--	--	--	--	--

Centre name .....

Time of the practical session .....

Laboratory name/number .....

**Give details of any difficulties experienced by the centre or by candidates (include the relevant candidate names and candidate numbers).**

You must include:

- any difficulties experienced by the centre in the preparation of materials
- any difficulties experienced by candidates, e.g. due to faulty materials or apparatus
- any specific assistance given to candidates.

Space for supervisor to record results, if relevant, e.g. temperature of the laboratory; results for Question 1.

### Declaration

- 1 Each packet that I am returning to Cambridge International contains the following items:
  - the scripts of the candidates specified on the bar code label provided
  - the supervisor's results relevant to these candidates
  - the supervisor's reports relevant to these candidates
  - seating plans for each practical session, referring to each candidate by candidate number
  - the attendance register.
- 2 Where the practical exam has taken place in more than one practical session, I have clearly labelled the supervisor's results, supervisor's reports and seating plans with the time and laboratory name/number for each practical session.
- 3 I have included details of difficulties relating to each practical session experienced by the centre or by candidates.
- 4 I have reported any other adverse circumstances affecting candidates, e.g. illness, bereavement or temporary injury, directly to Cambridge International on a *special consideration form*.

Signed ..... (supervisor)

Name (in block capitals) .....